



# The curd mill

## E-Z CUT CURD MILL™



Attention  
objet tranchant  
Caution  
sharp object



The EBR curd mill is tailor-made to the needs of the cheese industry. Its custom design and rugged stainless steel construction makes it the most efficient and easy-to-clean machine on the market.

## Standard features

- **New** weight balance
- **Better** positioning including friction tips
- Superior milling
- Square curd shape
- Easy to clean
- All stainless steel
- Left or right feeding
- No bushing or gear
- No tilt mechanism
- Reduced power requirement
- Quick change cutting carriage
- Two capacities:  
5.500 Lbs/hr and 11.000 Lbs/hr

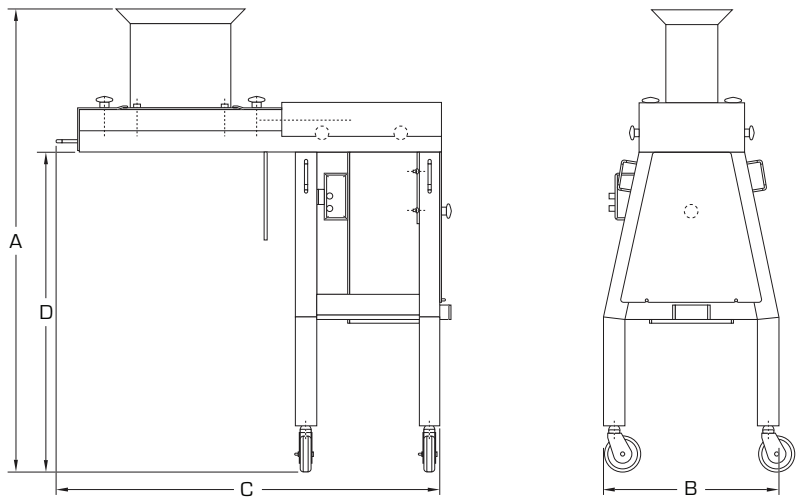

Features	Model EBR-7-MF	Model EBR-11-MF
----------	-------------------	--------------------

<b>Height (A):</b>	56 1/2"	56 1/2"
<b>Width (B):</b>	24 1/2"	24 1/2"
<b>Depth (C):</b>	53 1/2"	66 1/4"
<b>Discharge Height (D):</b>	To be determined	To be determined
<b>Voltage:</b>	As request	As request
<b>Horse Power:</b>	1 HP	1.5 HP
<b>Capacity:</b>	5.500 Lbs/hr	11.000 Lbs/hr
<b>Curd Size:</b>	As request	As request
<b>Funnel dimensions:</b>	11" x 17 1/2"	14 1/2" x 23 3/4"



1-800-463-7202

P: 418.871.1132

F: 418.871.4720

[ebr-inc@ebrequipment.com](mailto:ebr-inc@ebrequipment.com)

5415, Rideau Street, Quebec City (Quebec) Canada G2E 5V9

